

# Handbook for hazardous area solution No. 14 - AB - INC

## Incremental encoder with a safety barrier series 14 – AB incremental

UL 216028 for hazardous areas class 1 group A B C D  
Certified to EEx ia IIBT4



To complete this handbook please download

Encoder [www.encoderonline.com/UK/Data-Sheets/Incremental/Data-14.htm](http://www.encoderonline.com/UK/Data-Sheets/Incremental/Data-14.htm)

Barrier [www.encoderonline.com/UK/Data-Sheets/Barriers/Data-AB.htm](http://www.encoderonline.com/UK/Data-Sheets/Barriers/Data-AB.htm)

Solution [www.encoderonline.com/UK/Data-Sheets/Solutions/Data-14-AB.htm](http://www.encoderonline.com/UK/Data-Sheets/Solutions/Data-14-AB.htm)

Part number 14 XX 13 XX XXXX AB  
shaft outlet resolution

The complete solution consists of an Encoder, a barrier and 25 ft cable packed in a hard box and marked on the top  
HS tariff number 9031.80.99.94

### Content

Page 1 this title

Page 2 Record keeping

Page 3 Mechanical and electrical installation

Page 4 Installation and Maintenance Information for Hazardous Area

Page 5 Warranty

Page 6 Contact addresses

## Record keeping

Electrical apparatus which is to be used in a potentially flammable atmosphere needs to be designed to exacting standards to ensure that it will not cause ignition of the flammable atmosphere. There are various protection concepts which are used to provide this security and Hohner has a range of products which have been designed specifically for hazardous locations. These products fully meet the requirements of European and American standards and where appropriate, have been certified by an EC nominated body. Apparatus which is to be used in hazardous areas must be carefully installed and maintained. Installations should conform to the guidance of the appropriate code of practice.

Hazardous area terminology :

Gas table with some typical gases :

Gas Groups in EU	Gas Groups in US	Typical Hazards
IIC	Class I Group A	Acetylene
IIC	Class I Group B	Hydrogen
IIB	Class I Group C	Ethylene
IIA	Class I Group D	Propane Methane

Presence of hazardous atmosphere

EU	US
Zone 0 = likely to be present continuously	Division 1 present under normal conditions
Zone 1 = may be present at some time	Division 2 present under fault conditions
Zone 2 = present under fault conditions.	

The temperature classification specifies the maximum temperature which may be exhibited by the electrical apparatus .

- T1 = 450 degrees ,
- T2 = 300 degrees ,
- T3 = 200 degrees ,
- T4 = 135 degrees ,
- T5 = 100 degrees ,
- T6 = 85 degrees

Most important records be kept

Risk assessment

Hazard specification      Gas group .....

   Presence of hazardous atmosphere.....

   Temperature classification.....

Installation of equipment in hazardous location

Installed equipment      Encoder series 14

   Electrical - like cable – earth clamps etc.....

   Mounting – like coupling – flange etc .....

   Electrical connection outside like barrier series AB

## Mechanical and electrical installation

### Electrical installation

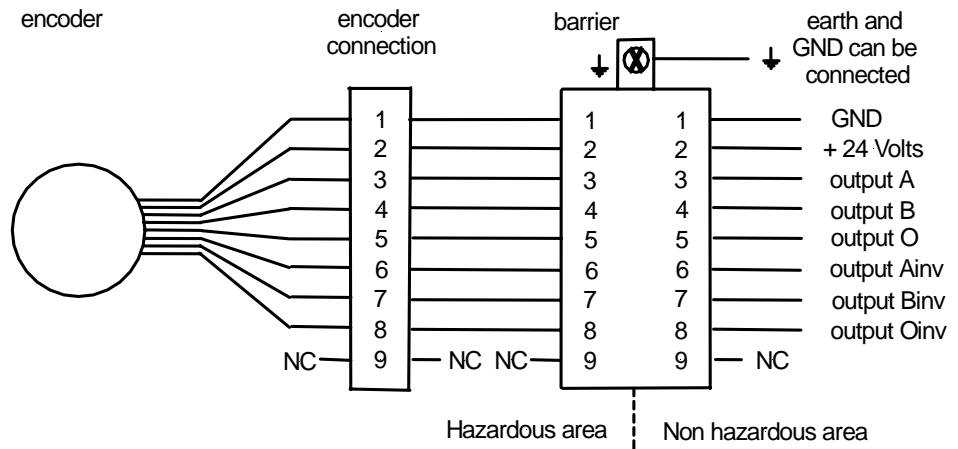

Mount safety barrier in a metal enclosure outside the hazardous area and connect earth as demonstrated

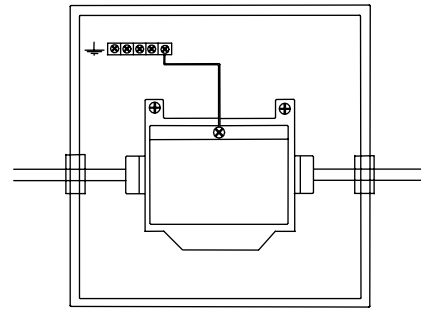

### Mechanical installation

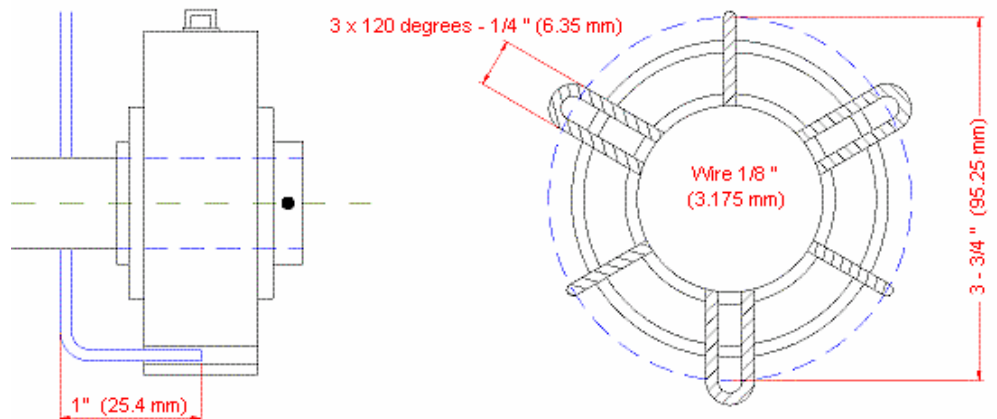

#### Instructions:

First mount spider. Slide encoder over the spider. Tighten the setscrew to shaft. Hook up the encoder with the electronics as described. Make sure power supply meets specifications. Switch on power supply only after connections are connected. Encoder can be mounted either side, with the setscrew outside or inside

**Caution:** Any of these actions will void the warranty and damage the product:

- Do not shock the encoder
- Do not dismantle the encoder
- Do not tool the encoder or its shaft
- Do not subject the encoder to axial or radial stresses
- Do not use makeshift techniques to mount the encoder

## Installation and Maintenance Information for Hazardous Area

These notes are intended for guidance purposes. They do not replace the information and requirements given in official documents. Hazardous area installations must conform to the requirements of the country of use. Apparatus must not be installed in hazardous areas which are more severe than the encoder safety description. The safety description is marked on accompanying documents and on the label of the apparatus.

Ensure that a record is kept of the apparatus installed in the hazardous area. As detailed in the relevant code of practice, it is essential that regular inspections are carried out on all equipment to ensure that it remains in a good condition without undue corrosion. The condition of cable, gland and mechanical mounting should also be checked.

When installing the encoder ensure that it is securely mounted and that any external earth connection facility is connected to a suitable bonding conductor whose remote end is connected to nearby plant metalwork to ensure equipment potential bonding of the apparatus. On no account modify the apparatus in any way, and do not fix plant identification labels to the encoder by drilling holes for self tapping screws etc. Any plant identification should either be fixed with adhesive or fitted to nearby plant structure. Ensure that the certification label can still be read with the apparatus in the installed position.

Caution :

Do not subject the unit to excessive shock or vibration.

Do not subject the unit to a mechanical environment in excess of that for which it is specified.

Do not leave any unused in / out wires without protective insulation.

Do not apply more supply voltage than the specified maximum.

Do not exceed the maximum power dissipation specified.

Do not connect or disconnect any wires with power present.

Do not coil excess cable.

Do not make cable longer than actually required.

Do not short outputs together or connect to any point other than that of the interfacing equipment.

Do not leave screen disconnected.

Electro - Magnetic Precautions:

Although Hohner has designed a great deal of noise immunity into the product in accordance with EN50081 - 2 and EN50082 - 2, it is still very important to use good Electro Magnetic Compatibility techniques on installation of both this and associated electronic equipment, to ensure reliable operation both short and long term.

Encoder cable should be routed to avoid close proximity to cables carrying high levels of current or rapid switching transients. It is also recommended that those power cables be suppressed using ferrites or similar noise suppressing components. For improved noise immunity twisted pair and shielded cable should be used and each output should be driven in differential mode (i.e. with compliments). It is further suggested that the cable screen is connected all around the circumference of the cable to earth, instead of twisting it to one side. With this method a more effective level of shielding will be achieved. Do not connect the shield from the cable with the encoder housing.

## Warranty

Scope. All orders are subject **Page 4** and conditions. No salesperson or other party is authorized to bind **Page 4** by any agreement, warranty, statement, promise or understanding not herein expressed, and no modifications shall be binding on Seller unless same are, in writing and signed by an executive of seller or his duly authorized representative. Verbal orders will not be executed until written notification has been received by Seller and properly acknowledged by Seller.

Warranty. Seller warrants its products against defects in the workmanship and materials of the items purchased under this order provided, however, that notice of such defect is received in writing by Seller within one year from date of delivery of the item under this order. Seller's liability under this clause is restricted to replacing, repairing, or issuing credit (at Seller's option) for any returned unit and only under the following conditions:

Seller must be promptly notified in writing as soon as possible after defects have been noted by the customer but no later than one year from date of delivery. The defective merchandise is to be returned to place of manufacture, shipping charges prepaid by the customer. Our inspection of the returned units shall disclose to our satisfaction that the units were defective in workmanship or materials at the time of delivery. Warranty will become null and void if product is tampered with. Mounting instructions must be followed to maintain warranty coverage. All other warranties, for any of Seller's products, expressed or implied, statutory or otherwise, including without limitation any implied warranty of merchantability or fitness for purposes are excluded.

Returns and Adjustments. No unit may be returned unless authorized in advance and agreed to by Seller and then only upon such conditions as Seller may agree to. Buyer shall be responsible for the unit returned until such time as Seller receives the same at its plant and for all charges for packaging, inspection, shipping or transportation or insurance associated with returned material. In the event that credit for returned materials is granted, it shall be at the prices in effect as of the date of any original shipment of the unit by Seller. Claims for shortage or incorrect material must be made within 5 days after receipt of shipment.

Limitation of Liability. Seller's liability for any claim of any kind (except) "Protection against infringement shall not exceed purchase price of any goods which give rise to the claim. Seller shall in no event be liable for Buyer's manufacturing costs, lost profits, goodwill or other special or consequential damages. Seller can not be made responsible for any application of its devices nor does the Seller recommend the use of its devices in life support.

## Contact addresses

Hohner Automation Ltd.

Units 14 – 16

Whitegate Industrial Estate Wrexham Wales United Kingdom LL13 8UG

Tel. 44 – 1978 363 888

Fax. 44 – 1978 364 586

[www.intrinsicallysafe.com](http://www.intrinsicallysafe.com)

e-mail [uksales@hohner.com](mailto:uksales@hohner.com)

Hohner Corp.

5536 Regional Road 81 Beamsville Ontario Canada LOR 1B3

Tel. 1 – 905 563 4924

Fax. 1 – 905 563 7209

[www.intrinsicallysafe.com](http://www.intrinsicallysafe.com)

e-mail [hohner@hohner.com](mailto:hohner@hohner.com)

Hohner Electronica Ltda.

Rua Joao Bombo 754

Parque Industrial Itamaraty Artur Nogueira , Sao Paulo Brasil CEP 13 160 000

Tel. 55 – 1938 77 5214

FAX. 55 – 1938 77 1182

[www.intrinsicallysafe.com](http://www.intrinsicallysafe.com)

e-mail [hohner@terra.com.br](mailto:hohner@terra.com.br)

Hohner Inc.

24 Mariner Street Buffalo New York USA14201

[www.intrinsicallysafe.com](http://www.intrinsicallysafe.com)

e-mail [hohner@hohner.com](mailto:hohner@hohner.com)

Tel. 1 – 716 885 0446

Fax. 1 – 905 563 7209

Hohner Automaticos S.A.

Prolongacion c / Sant Francesc 17400 Breda Girona Spain

Tel. 34 – 972 160 017

Fax. 34 – 972 160 230

[www.intrinsicallysafe.com](http://www.intrinsicallysafe.com)

e-mail [info@hohner.es](mailto:info@hohner.es)

Hohner Elektrotechnik GmbH

Gewerbehof 1 D 59368 Werne Germany

Tel. 49 – 2389 98780

Fax. 49 – 2389 987827

[www.intrinsicallysafe.com](http://www.intrinsicallysafe.com)

e-mail [info@Hohner-Elektrotechnik.de](mailto:info@Hohner-Elektrotechnik.de)

